

# Performance Analysis of a Newly Designed DC to DC Buck-Boost Converter

M. Iftekher Uddin\*, Kazi Samira Shamsi Huq, S M Salam

Dept of EEE, Chittagong University of Engineering and Technology,  
Pahartali Rd, Raozan, Chittagong 4349, Bangladesh

\*Corresponding author: iftekher28eee@gmail.com

(Received: 1<sup>st</sup> September 2022; Accepted: 13<sup>th</sup> September 2022)

**Abstract**—Most of the electronic devices operate on the principle of the voltage-controlled voltage source. With the improved technology and an increase in circuit complexity, the necessity of controlling the output voltage level irrespective of the change in the load current or line voltage is increasing at a tremendous rate. Moreover, battery dominated electronic devices and gadgets demand a wide range of variation and control over DC voltage and power, which currently faces many challenges. This study proposes a design of a DC to DC Buck-Boost converter and analyzes the converter's performance by placing the Pulse Width Modulation of 40% and 48% duty cycles for buck-mode and 66% and 100% for boost-mode in the switching circuit. The result is simulated in the Proteus Suite software.

**Keywords:** *Pulse Width Modulation (PWM), Metal Oxide Semiconductor Field Effect Transistor (MOSFET), Switched Mode Power Supply (SMPS), System on a Chip (SoC).*

## 1. INTRODUCTION

Under the progressive growth of wireless appliances, the demand for low supply voltage is rising. Consumer electronics such as laptop computers and personal communication devices require the lowest possible power supply voltage while maintaining computational throughput and quality of service. Moreover, the terminal voltage of the (NiMH, NiCd, and Li-ion) batteries in portable appliances varies according to the state of their charging condition. Therefore, the system designed with a supply voltage of nominal value requires a converter capable of both stepping-up (boost) and stepping-down (buck) [1, 2] the battery voltage. To achieve the requirement of various levels of DC output voltage under changing supply voltage and load current, a Buck-Boost converter with a smaller number of external components and cost effective SOC design is essential [3].

Control of switching power in DC to DC converter is a challenging task. The function of the control circuit in converter topologies is to nullify the effect of load variations, component tolerances, system aging and input source voltage. The invention of power electronic integrated circuits and solid-state switch-mode circuits has made the voltage regulation process cheaper and more efficient compared to pre-semiconductor ages.

The design of a high-performance control system in DC to DC converter is still challenging. However, among the controlling techniques, the technique that uses the duty cycle variation of PWM is considered the most reliable in the DC-DC power switching converter according to linear models [4, 5]. Two factors have made the control technique most effective, for it remains active for the one-half level of the switching frequency and can be implemented in both (voltage and current) modes.

### 1.1 Theory of Operation

A buck-boost converter essentially combines the function of a buck and a boost converter. In the boost mode, the converter supplies a higher output voltage to the load than the input voltage, whereas buck mode does the opposite. The Buck-Boost converter works on the periodic charging and discharging of the inductor and the capacitor.

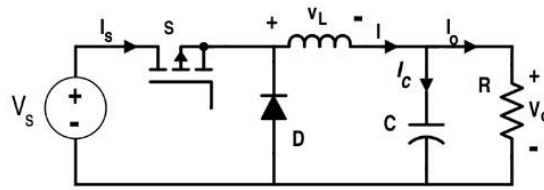

Fig. 1. Schematic of a Buck-Boost Converter

When the switch is on (figure 1), the inductor stores energy from the input in magnetic energy and the capacitor supplies the load. During the off state of the switch, the inductor dissipates its stored energy across  $R$  and  $C$ . Therefore, the capacitor in the output circuit is assumed to be large enough that the time constant of the RC circuit in the output stage is high. The large time constant compared to the switching period ensures that a constant output voltage  $V_o(t) = V_o$  exists across load terminals in a steady state.

The switch  $S$  is a MOSFET controlled by Pulse Width Modulation (PWM) signal. The main advantage of using a PWM signal in the switching device is the low power loss. In addition, the duty cycle of the PWM signal plays a significant role in the converter's efficiency.

There are two buck-boost converter operation modes based on the PWM signal's switching frequency.

1. Continuous Conduction Mode (CCM)
2. Discontinuous Conduction Mode (DCM)

In CCM, the current through the inductor never goes to zero. Therefore, the inductor partially discharges earlier than the switching cycle. In DCM, the current through the inductor discharges completely at the end of the switching cycle.

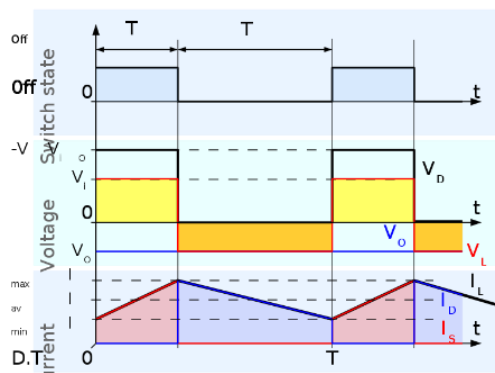

Fig. 2. Converter Operating at Continuous Mode

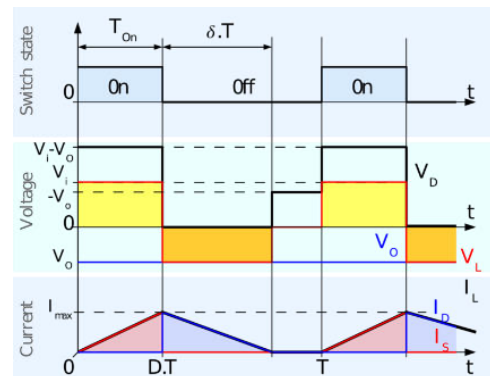

Fig. 3. Converter Operating at Discontinuous Mode

## 1.2 Experimental Setup: Block Diagram

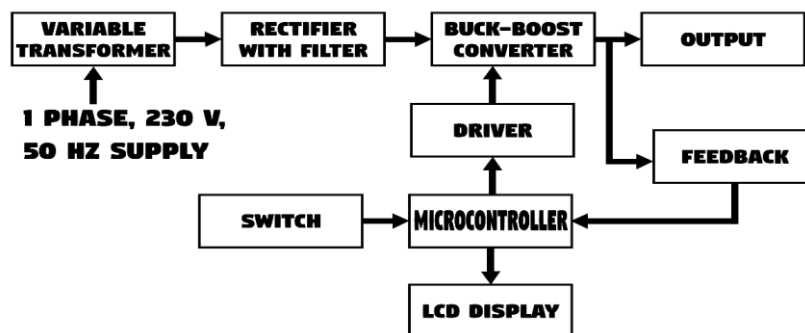

Fig. 4. Block Diagram of the Buck-Boost Converter

### 1.3 Equipment

Table 1: Parametric Values of the Buck-Boost Converter

Parameter	Value	Parameter	Value
Input inductor	150 $\mu$ H	Load resistance	1 $\Omega$
Input capacitor	220 $\mu$ F	MOSFET	IRFP480
Series capacitor with MOSFET	6 $\mu$ F	Microcontroller	PIC16F873
Series resistance with switching circuit	22K	Opto-coupler	TLP-250
Input resistance	22K	Diode	1N4007
Feedback resistance	2K	Switching frequency	31KHz

### 1.4 Circuit Diagram

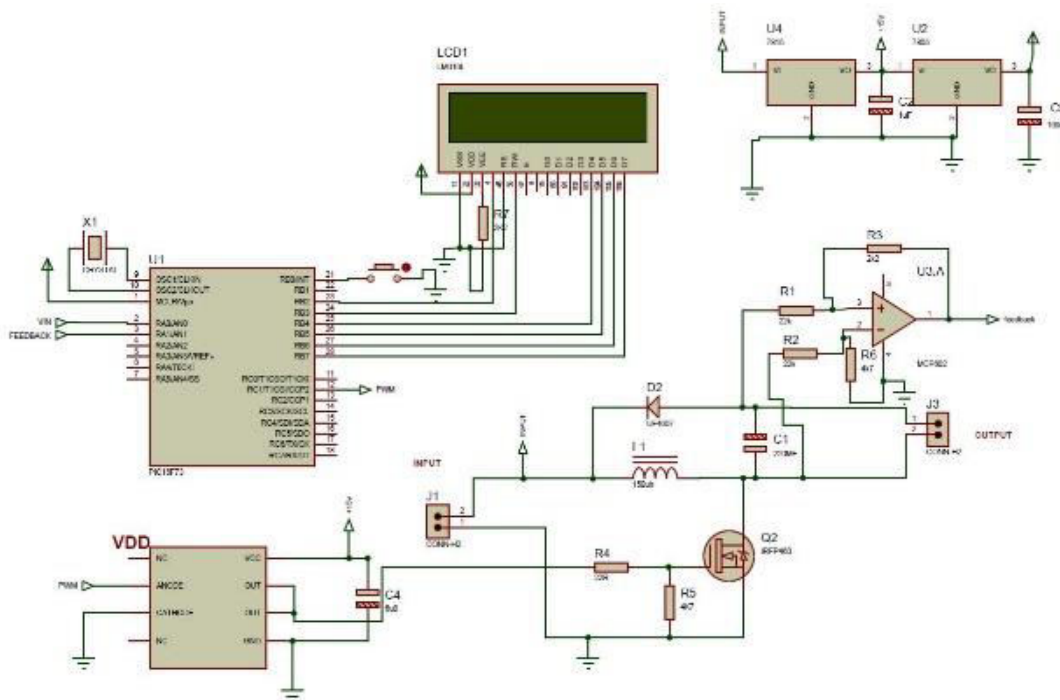

Fig. 5. Circuit Diagram

## 2. SIMULATION

The circuit simulation in Proteus performed using the following steps.

- i) Configuring Buck-Boost converter circuit on the Proteus software
- ii) Simulating the converter circuits under various duty cycles of PWM signal.
- iii) Result analysis

### 2.1 Buck Converter

Table 2: Buck Converter Simulation Data at 48 % and 40% Duty Cycle

Frequency	Period	Capacitance	Inductance	On Time $T_{on}$	Off Time $T_{off}$	Duty Cycle	Input Voltage	Output Voltage
31 KHz	32 $\mu$ s	220 $\mu$ F	150 $\mu$ H	12.8 $\mu$ s	19.2 $\mu$ s	40	29V	25V
				15 $\mu$ s	17 $\mu$ s	48	25V	24.5V

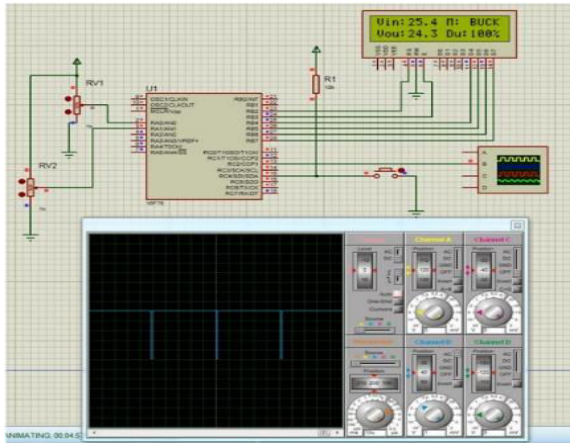

Fig. 6. Buck Mode Simulation with PWM of 48% Duty Cycle

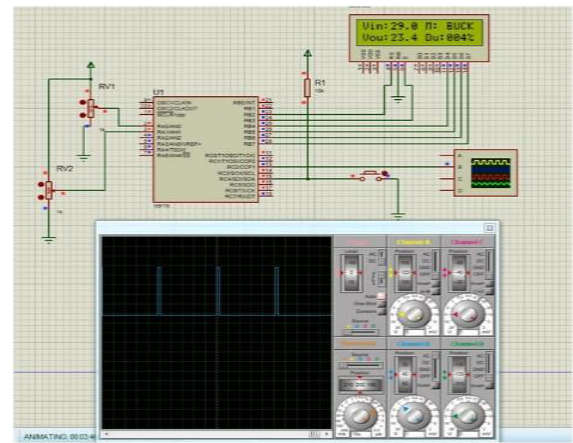

Fig. 7. Simulation of Buck Mode with PWM of 40% Duty Cycle

## 2.2 Boost Converter

Table 3: Boost Converter Simulation Data at 66% and 100% Duty Cycle

Frequency	Period	Capacitance	Inductance	On Time $T_{on}$	Off Time $T_{off}$	Duty Cycle	Input Voltage	Output Voltage
31 KHz	32 $\mu$ s	220 $\mu$ F	150 $\mu$ H	21.12 $\mu$ s	10.88 $\mu$ s	66%	23 V	25.5 V
				32 $\mu$ s	0 $\mu$ s	100%	23.4 V	24.3 V

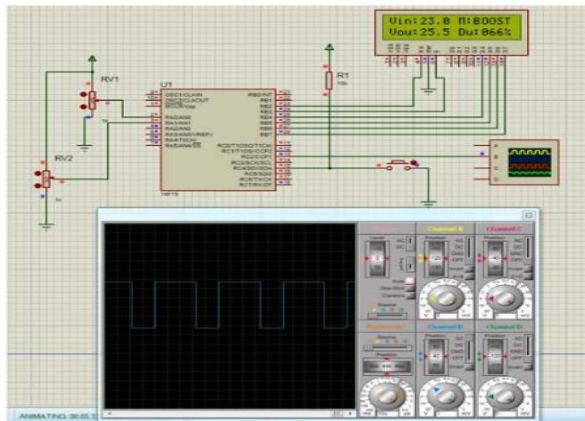

Fig. 8. Boost Mode with PWM of 66% Duty Cycle

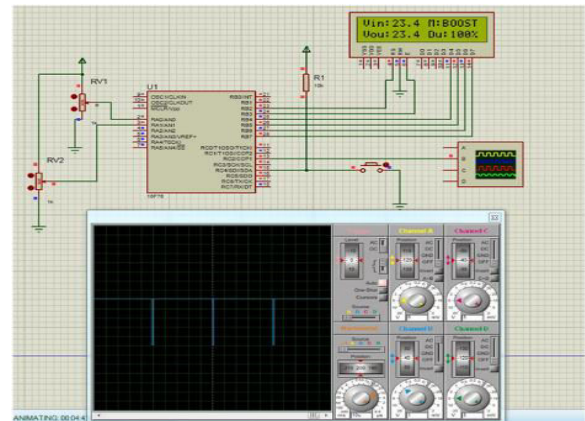

Fig. 9. Boost Mode with PWM of 100% Duty Cycle

For voltage conversion at  $D = 0.5$ ; where  $D$  is the duty cycle of the PWM signal.

Table 4: Converter Simulation Data at 51% Duty Cycle

Parameters	Value
Frequency	31KHz
Period	32 $\mu$ s
Duty cycle	51%
On Time, $T_{on}$	16.32 $\mu$ s
Off Time, $T_{off}$	15.68 $\mu$ s
Capacitance	220 $\mu$ F
Inductance	150 $\mu$ H
Input voltage	23.4V
Output voltage	23.4V

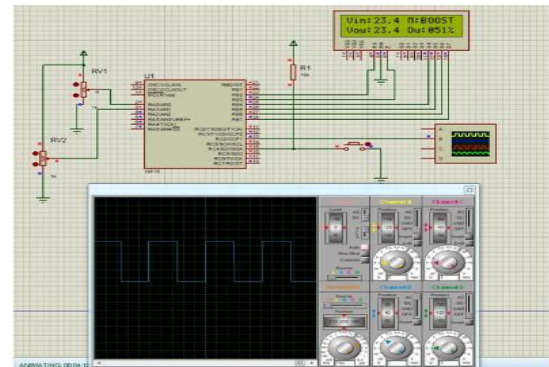

Fig. 10. Converter Operated at PWM of 51% Duty Cycle

### 2.3 Result Analysis

Table 5: Summary of Result

Modes of Converter	Duty Cycle of PWM	Efficiency
Buck mode	40%	81%
	48%	98%
Boost mode	66%	36%
	100%	0

From the above data table and simulation result, it is evident that in buck mode operation, using  $\frac{\text{Output Voltage}}{\text{Input Voltage}} = \text{Conversion Efficiency} = D$ , efficiency increases with the increasing percentage of duty cycle up to 50%. For the boost mode of operation, using  $\frac{V_{out}-D.V_{out}}{V_{in}} = \text{conversion efficiency}$ , efficiency decreases with the increasing percentage of duty cycle and becomes zero at  $D = 100\%$  [6, 7, 8]. Obviously, the converter operates at less than 100% duty cycle in boost mode. The primary power losses in a boost converter are mainly due to power switching losses, MOSFET conduction losses and DIODE switching and conduction losses.

### 3. CONCLUSION

A buck-boost converter provides a wide range of DC voltage and current variation that is optimal for use in modern gadgets and devices. The simplicity of controlling the switching signal's duty cycle has revolutionized the converter's use in digital electronic applications. This study suggests using the converter's Continuous Conduction Mode (CCM) in low voltage, high current applications. In contrast, the Discontinuous Conduction Mode (DCM) is in case of high voltage low current applications. The efficiency in the later is lower, which is not a limiting factor in low power conditions.

### REFERENCES

- [1] Abdessamad, B, Salah-ddine, K & Mohamed, C 2012, "Designing a High Efficiency Pulse Width Modulation Step-Down DC/DC Converter for Mobile Phone Applications", IJCSI International Journal of Computer Science Issues, vol. 9, no. 3, viewed 10th March 2020.
- [2] Elbakkar, K & Slaoui, K 2011, "Integrated Circuit of CMOS DC-DC Buck Converter with Differential Active Inductor", IJCSI International Journal of Computer Science Issues, vol. 8, no. 6, viewed 10 March 2020.
- [3] Langyuan, W & Xiaobo, W 2009, "A Multi-Mode Four-Switch Buck-Boost DC/DC Converter", IEEE Power and Energy Engineering Conference, viewed 10th March 2020.
- [4] Erickson, R & Maksimovic, D 2012, Fundamentals of Power Electronics, Springer, New York.
- [5] Langyuan, W & Xiaobo, W 2009, "A Multi-Mode Four-Switch Buck-Boost DC/DC Converter", IEEE Power and Energy Engineering Conference, viewed 10th March 2020.
- [6] Ngamkong, P, Kochcha, P, Areerak, K, Sujitjorn, S & Areerak, K 2020, "Applications of the generalized state-space averaging method to modelling of DC-DC power converters", Mathematical and Computer Modelling of Dynamical Systems, vol. 18, no. 3, pp. 243-260, viewed 10th March 2020.
- [7] Parvathy, P & Devarajan, N 2012, "Simulation and Implementation of Current-Fed Fullbridge Boost Converter with Zero Current Switching for High Voltage Applications", IJCSI International Journal of Computer Science Issues, vol. 9, no. 3, viewed 10th March 2020.
- [8] Simpson, C 2003, Characteristics of Rechargeable Batteries, SNVA533, National Semiconductor, viewed 10th March 2020, <<http://www.ti.com/lit/an/snva533/snva533.pdf>>.